

**IL1776**

## MICROPOWER PROGRAMMABLE OPERATIONAL AMPLIFIER

This extremely versatile operational amplifier features low power consumption and high input impedance. In addition, the quiescent currents within the device may be programmed by the choice of an external resistor value or current source applied to the  $I_{set}$  input. This allows the amplifier's characteristics to be optimized for input current and power consumption despite wide variations in operating power supply voltages.

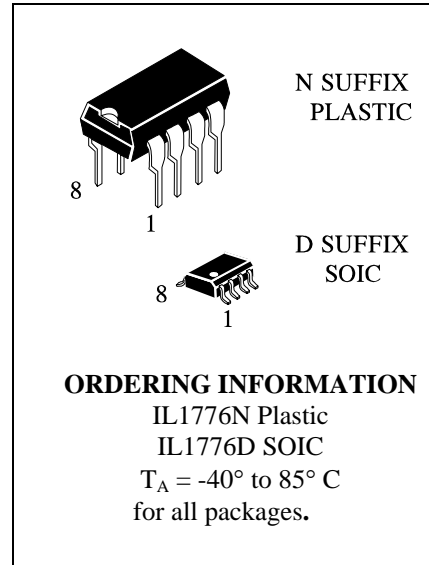

### FEATURES

Supply Operation	$\pm 1,2 - \pm 18$ V
Input Bias Current	2nA typ
Input Offset Current	0,7 nA typ
Input Offset Voltage	2 mV typ
Large Signal Voltage Gain	$\geq 50$ k V/V
Low Current Drain	
Wide Programming Range	
Offset Null Capability	
Short Circuit Protection	
Internally Frequency Compensated for Unity Gain	

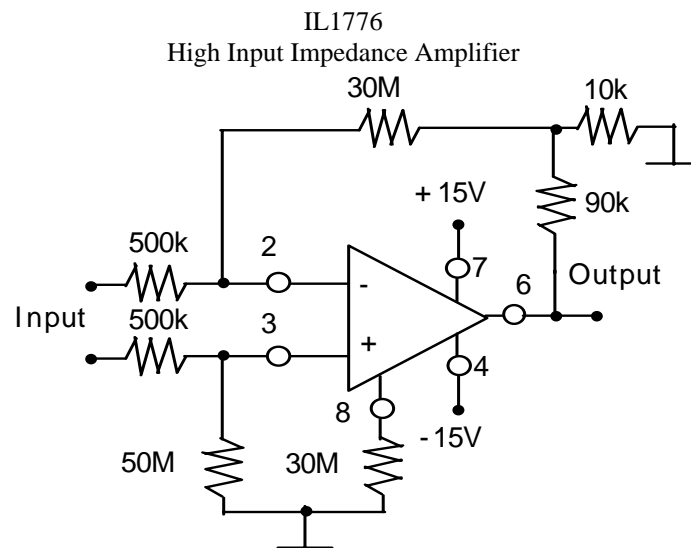
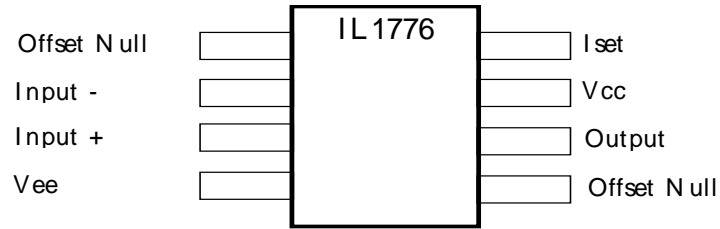

Multiple Feedback Bandpass Filter (1.0kHz)

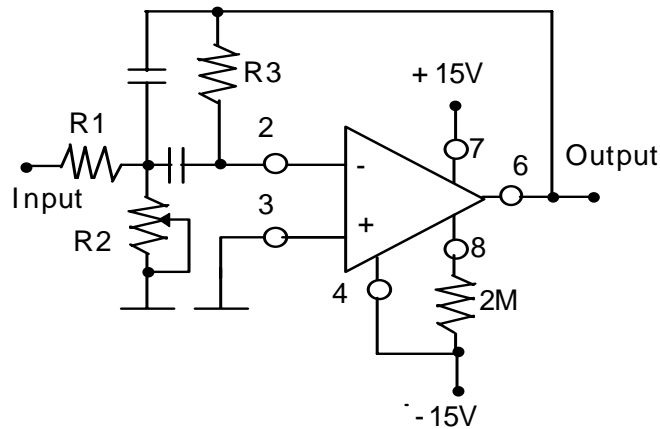

**N SUFFIX PLASTIC DIP  
(MS - 001BA)**

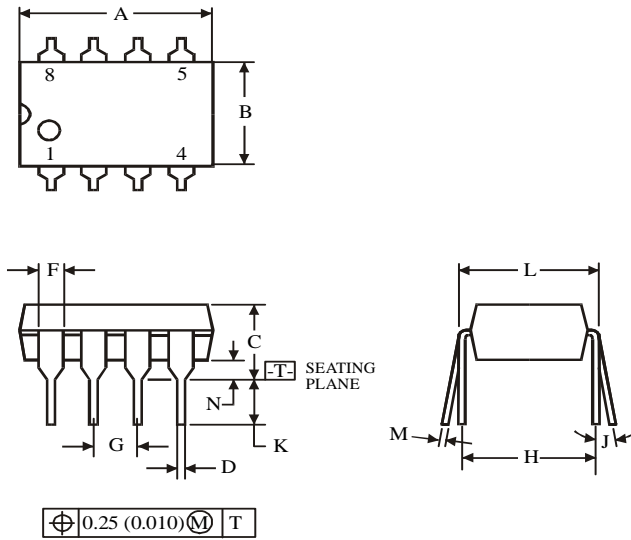
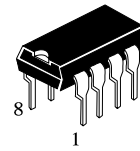

Symbol	Dimension, mm	
	MIN	MAX
A	8.51	10.16
B	6.1	7.11
C		5.33
D	0.36	0.56
F	1.14	1.78
G	2.54	
H	7.62	
J	0°	10°
K	2.92	3.81
L	7.62	8.26
M	0.2	0.36
N	0.38	

**NOTES:**

- Dimensions "A", "B" do not include mold flash or protrusions.  
Maximum mold flash or protrusions 0.25 mm (0.010) per side.

**D SUFFIX SOIC  
(MS - 012AA)**

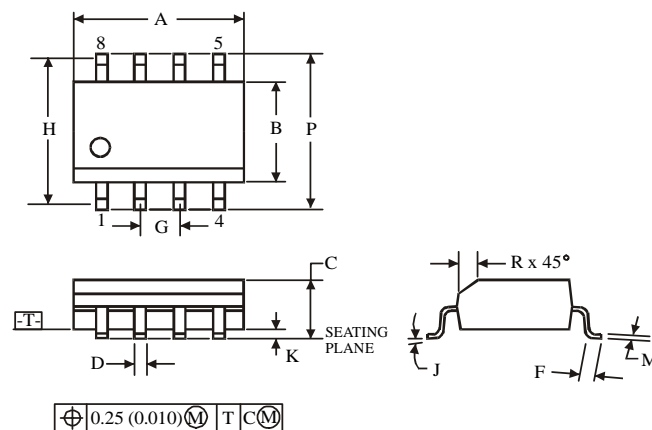
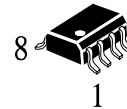

Symbol	Dimension, mm	
	MIN	MAX
A	4.8	5
B	3.8	4
C	1.35	1.75
D	0.33	0.51
F	0.4	1.27
G	1.27	
H	5.72	
J	0°	8°
K	0.1	0.25
M	0.19	0.25
P	5.8	6.2
R	0.25	0.5

**NOTES:**

- Dimensions A and B do not include mold flash or protrusion.
- Maximum mold flash or protrusion 0.15 mm (0.006) per side for A; for B - 0.25 mm (0.010) per side.